

MODEL: 27-GEL

DIMENSIONS: inches (mm)

BATTERY: VRLA GEL

COLOR: Maroon (case) Grey (cover)

MATERIAL: Polypropylene



PRODUCT SPECIFICATIONS

BCI GROUP SIZE	TYPE	CAPACITY ^A Amp-Hours (AH)								ENERGY (kWh)	VOLTAGE	TERMINAL Type ^{D**}	DIMENSIONS ^B Inches (mm)			WEIGHT lbs. (kg)
		2-Hr Rate	5-Hr Rate	10-Hr Rate	20-Hr Rate	48-Hr Rate	72-Hr Rate	100-Hr Rate	100-Hr Rate				Length	Width	Height ^C	
DEEP-CYCLE GEL BATTERIES																
27	27-GEL	60	76	84	91	97	99	100	1.20	12 VOLT	7	12.73 (323)	6.38 (162)	9.26 (235)	63 (29)	

CHARGING INSTRUCTIONS

CHARGER VOLTAGE SETTINGS (AT 77°F/25°C)				
System Voltage	12V	24V	36V	48V
Absorption Charge	14.1 – 14.4	28.2 – 28.8	42.3 – 43.2	56.4 – 57.6
Float Charge	13.5	27	40.5	54

Do not install or charge batteries in a sealed or non-ventilated compartment. Constant under or overcharging will damage the battery and shorten its life as with any battery.

CHARGING TEMPERATURE COMPENSATION

.028 VPC for every 10°F (5.55°C) above or below 77°F (25°C) (add .028 VPC for every 10°F (5.55°C) below 77°F and subtract .028 VPC for every 10°C above 77°F).

EXPECTED LIFE VS. TEMPERATURE

Chemical reactions internal to the battery are driven by voltage and temperature. The higher the battery temperature, the faster chemical reactions will occur. While higher temperatures can provide improved discharge performance the increased rate of chemical reactions will result in a corresponding loss of battery life. As a rule of thumb, for every 10°C increase in temperature the reaction rate doubles. Thus, a month of operation at 35°C is equivalent in battery life to two months at 25°C. Heat is an enemy of all lead acid batteries, FLA, AGM and gel alike and even small increases in temperature will have a major influence on battery life.

OPERATIONAL DATA

Operating Temperature	Self Discharge
-4°F to 113°F (-20°C to +45°C). At temperatures below 32°F (0°C) maintain a state of charge greater than 60%.	Less than 3% per month depending on storage temperature conditions.

Batteries may be utilized at higher temperatures with the understanding that battery life will be reduced by 50% for every 10° C (18° F) increase in operating temperatures over 68° F (20° C).

- A. The amount of amp-hours (AH) a battery can deliver when discharged at a constant rate at 77°F (25°C) and maintain a voltage above 1.75 V/cell. Capacities are based on peak performance.
- B. Dimensions are based on nominal size. Dimensions may vary depending on type of handle or terminal.
- C. Dimensions taken from bottom of the battery to the highest point on the battery. Heights may vary depending on type of terminal.
- D. Terminal images are representative only.
- Trojan's battery testing procedures adhere to both BCI and IEC test standards.
- ** Additional Terminals Available

TERMINAL CONFIGURATIONS

7	UT	Universal Terminal
		<i>Terminal Height Decimals (mm)</i> 1.10 (28)
		<i>Torque Values in-lb (Nm)</i> 95-105 (11 – 12) <i>Bolt</i> 5/16"

27-GEL DATA SHEET

for Renewable Energy / Hybrid Systems / Backup Power Applications

BATTERY DIMENSIONS (shown with UT)

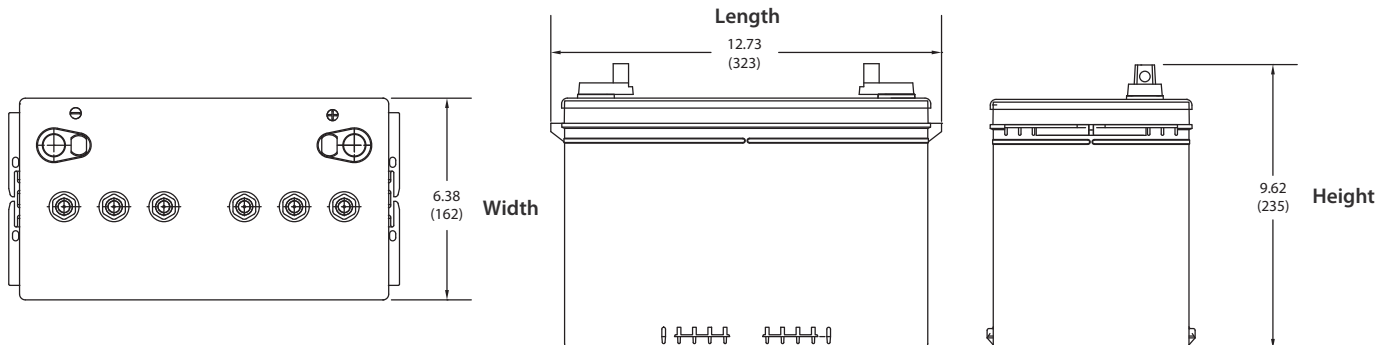

TROJAN 27-GEL PERFORMANCE

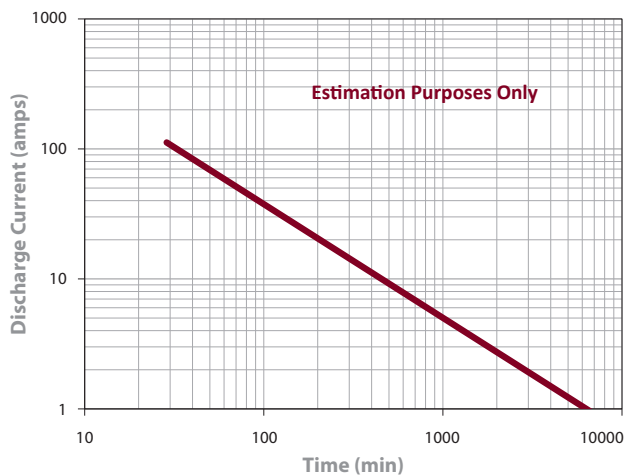

PERCENT CAPACITY VS. TEMPERATURE

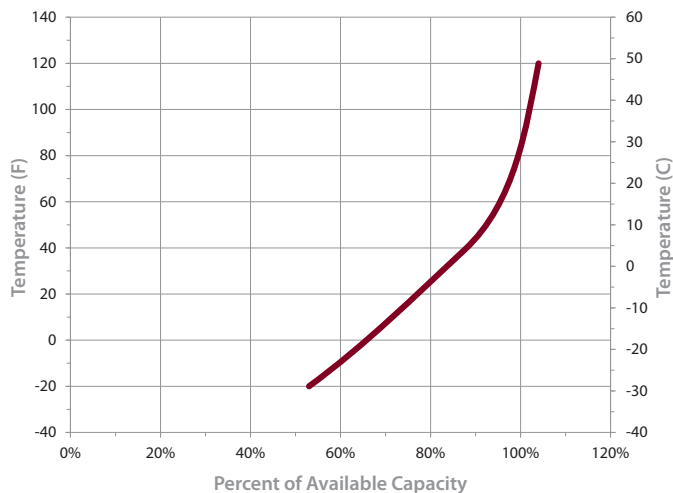

TYPICAL CYCLE LIFE IN A STATIONARY APPLICATION

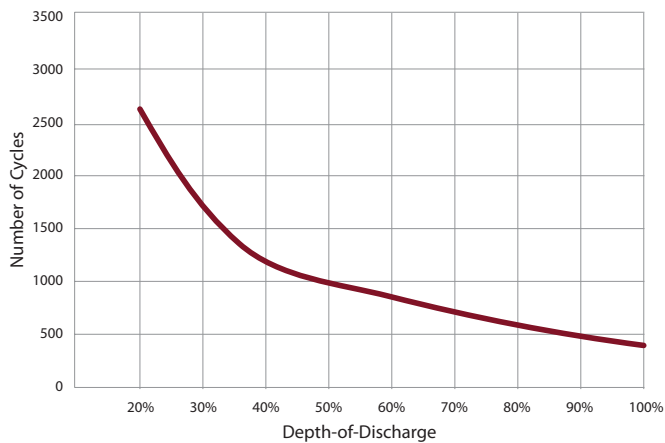

Trojan batteries are available worldwide.

We offer outstanding technical support, provided by full-time application engineers.

call 800.423.6569 or + 1.562.236.3000 or visit www.trojanbatteryRE.com

12380 Clark Street, Santa Fe Springs, CA 90670 • USA or email re@trojanbattery.com